



## Description

The Arduino® MKR IoT Carrier provides infinite possibilities for IoT projects.

The integrated sensors, circuits and display leave you free to focus on programming and prototyping your ideas.

## Target areas:

IoT applications, MKR hobbyists

## Features

*Note: This board is passive and requires a MKR board to function.*

- **Grove Connectors**
  - Easy interface with wide range of Grove modules and sensors
  - 2x analog sensor input
  - 1x I2C interface
- **ST LSM6DS3 6-axis IMU Sensor**
  - 3-axis accelerometer  $2/\pm 4/\pm 8/\pm 16$  g full scale
  - 3-axis gyroscope  $125/\pm 250/\pm 500/\pm 1000/\pm 2000$  dps (degrees per second)
  - I2C interface to Arduino MKR board
  - Low power consumption (0.55mA max)
- **Rounded 1.3" TFT Display**
  - 240 x 240 resolution
  - 36 x 40 mm
- **ST HTS221 Humidity Sensor**
  - Capacitive sensing
  - 0-100% humidity sensing range
  - Humidity accuracy:  $\pm 3.5\%$  rH, 20 to +80% rH
  - Temperature accuracy:  $\pm 0.5$  °C, 15 to +40 °C
  - I2C interface to Arduino MKR board
  - Low power consumption (2 $\mu$ A @ 1 Hz sampling rate)
- **Broadcom APDS-9660 RGB and Gesture Sensor**
  - Ambient light and RGB Color Sensing
  - Proximity Sensing
  - Gesture Detection
  - UV/IR Blocking Filter
  - I2C interface to Arduino MKR board
- **ST LPS22HBTR Pressure Sensor**
  - 260 to 1260 hPa (0.25 to 1.24 atm) absolute pressure range
  - I2C interface to Arduino MKR board

**▪ Relays**

- 2x KEMET EE2-5NU-L relays
- 5V Coil voltage
- 2A Current
- 220V DC, 250V AC
- Non-latching
- Common, normally open and normally closed contacts
- LED Status Indicator

**▪ Peripherals**

- 5x Capacitive buttons
- Buzzer
- 5x Digital RGB LEDs
- Rounded OLED 1,3" Display
- 5x Capacitive qTouch buttons

**▪ Memory**

- Micro SD Card

**▪ Power**

- Li-ion 18650 3.7 v battery holder
- USB Battery charging via MKR board (Runs up to 48h with a 3.7v 2500mAh)

**▪ I/O**

- All sensors feature wake up function
- 2x Analog Grove connectors
- 1x I2C Grove connector
- 2x relay connector

**▪ Safety information**

- Class A



# Contents

<b>1 The Board</b>	<b>6</b>
1.1 Application Examples	6
1.2 Accessories	6
1.3 Related Products	6
<b>2 Functional Overview</b>	<b>7</b>
2.1 Board Topology	7
2.1.1 Front View	7
2.1.2 Back View	8
2.2 Power Tree	9
2.3 Solution Overview	10
<b>3 Board Operation</b>	<b>11</b>
3.1 Getting Started - IDE	11
3.2 Getting Started - Arduino Cloud Editor	11
3.3 Getting Started - Arduino Cloud	11
3.4 Sample Sketches	11
3.5 Online Resources	11
3.6 Board Recovery	12
<b>4 Connector Pinouts</b>	<b>12</b>
4.1 Battery Clips	13
4.2 A5	13
4.3 A6	13
4.4 I2C	13
4.5 Relay 1 / Relay 2	13
<b>5 Mechanical Information</b>	<b>14</b>
5.1 Board Outline / Mounting Holes	14
<b>6 Ratings</b>	<b>15</b>
6.1 Absolute Maximum Ratings	15
<b>7 Certifications</b>	<b>15</b>
7.1 Declaration of Conformity CE DoC (EU)	15
7.2 Declaration of Conformity to EU RoHS & REACH 211 01/19/2021	15
7.3 Conflict Minerals Declaration	16
<b>8 FCC Caution</b>	<b>16</b>
<b>9 Company Information</b>	<b>17</b>



<b>10 Reference Documentation</b>	<b>17</b>
<b>11 Revision History</b>	<b>18</b>



## 1 The Board

### 1.1 Application Examples

**Light controller:** Control your house lightning with the MKR IoT Carrier, using the RGB light sensor. This feature identifies the general amount of light in a room or environment and adapts. If the board is connected to Wi-Fi®, you can manage and control your device remotely on a smartphone via the Arduino Cloud.

**Light and water controller for greenhouse:** With moisture sensor, pressure sensor and temperature the MKR IoT Carrier can evaluate and recognize the moisture of the soil, depending on air humidity and sun. Through the various sensors, it can reconstruate suitable climate (e.g. tropical) with the help of heaters and relays to increase the humidity. It can also be programmed with a watering system thanks to the relays.

**Weather station:** With temperature sensor, pressure sensor, humidity sensor and light sensors, you can easily use your MKR IoT Carrier as a local weather station. The various sensors can via sensors collect statistics about the different variables required to display weather.

### 1.2 Accessories

- 18650 Li-ion battery
- Grove sensors

### 1.3 Related Products

- Arduino® MKR WiFi 1010 (SKU: ABX00023)
- Protective case
- Arduino® MKR Zero (SKU: ABX00012)

## 2 Functional Overview

### 2.1 Board Topology

#### 2.1.1 Front View

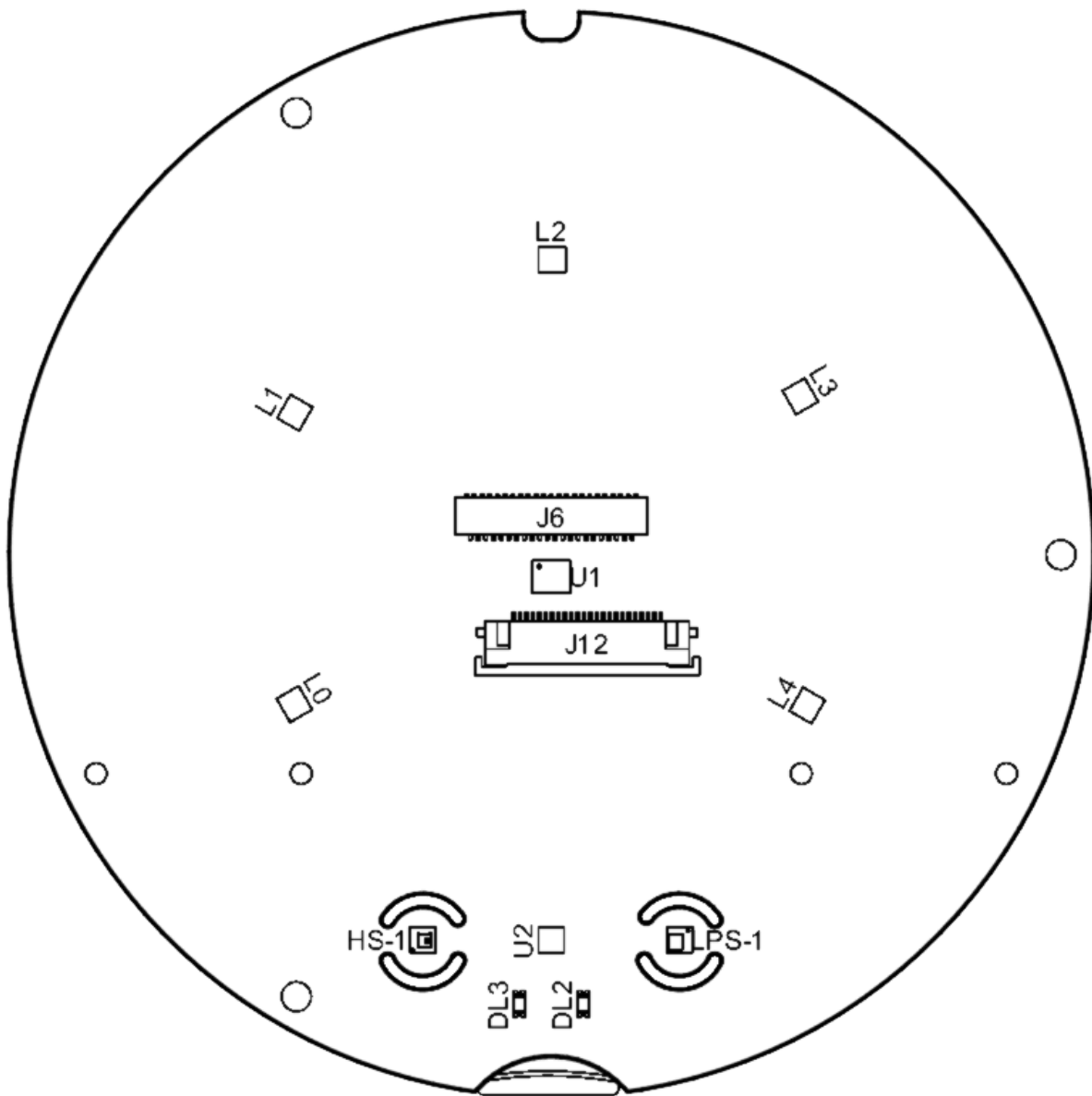

Front view

Ref.	Description	Ref.	Description
U1	LSM6DS3 6-axis IMU IC	U3	LV52204MTTBG LED Boost Driver IC
U2	APDS-9660 RGB and Gesture Sensor IC	HS-1	HTS221 Humidity Sensor IC
LPS-1	LPS22HBTR Pressure Sensor IC	L0-L4	APA1022020-2018 RGB LED IC

Ref.	Description	Ref.	Description
J6	FH26W-45S-0.3SHW(60) Display Connector	J12	SFV24R-1STBE1HLF Display Connector

### 2.1.2 Back View

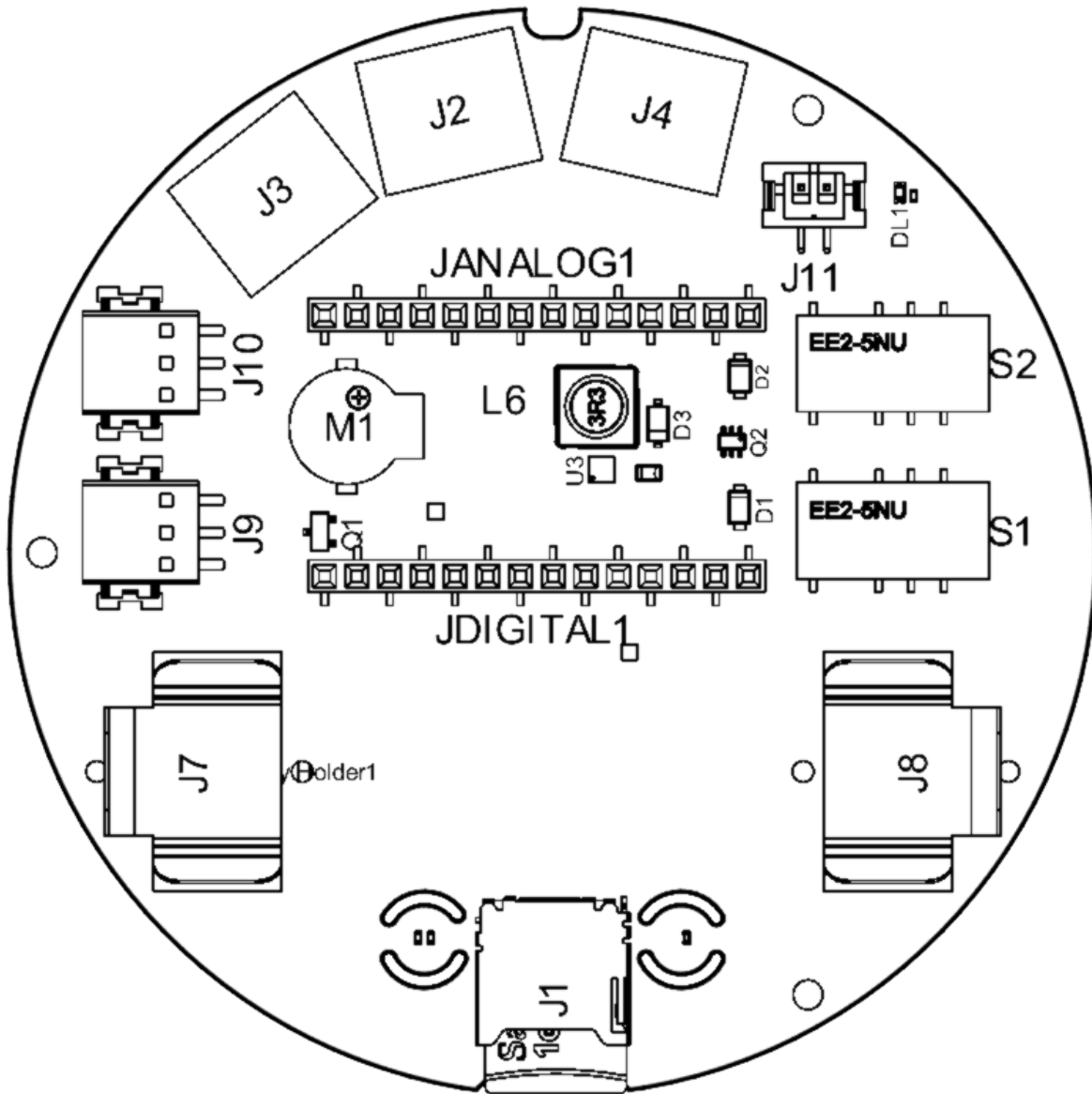

Bottom view

Ref.	Description	Ref.	Description
J2, J3	Analog Grove Connectors	J4	I2C Grove Connector
J11	B2B-PH-SM4-TB(LF)(SN) Power Connector	J9, J10	1771033 3-pin Relay Connector
JDIGITAL1	MKR Power and Digital Pin Connector	JANALOG1	MKR AREF and Analog Pin Connector
S1, S2	EE2-5NU-L 2A 250V Mechanical Relay	M1	Buzzer
J1	Micro SD Module	J7, J8	Li-Ion 18650 Holder

## 2.2 Power Tree

The MKR IoT Carrier makes use of the power management features of the Arduino MKR boards to power itself as well as to interface with the Li-Ion battery.

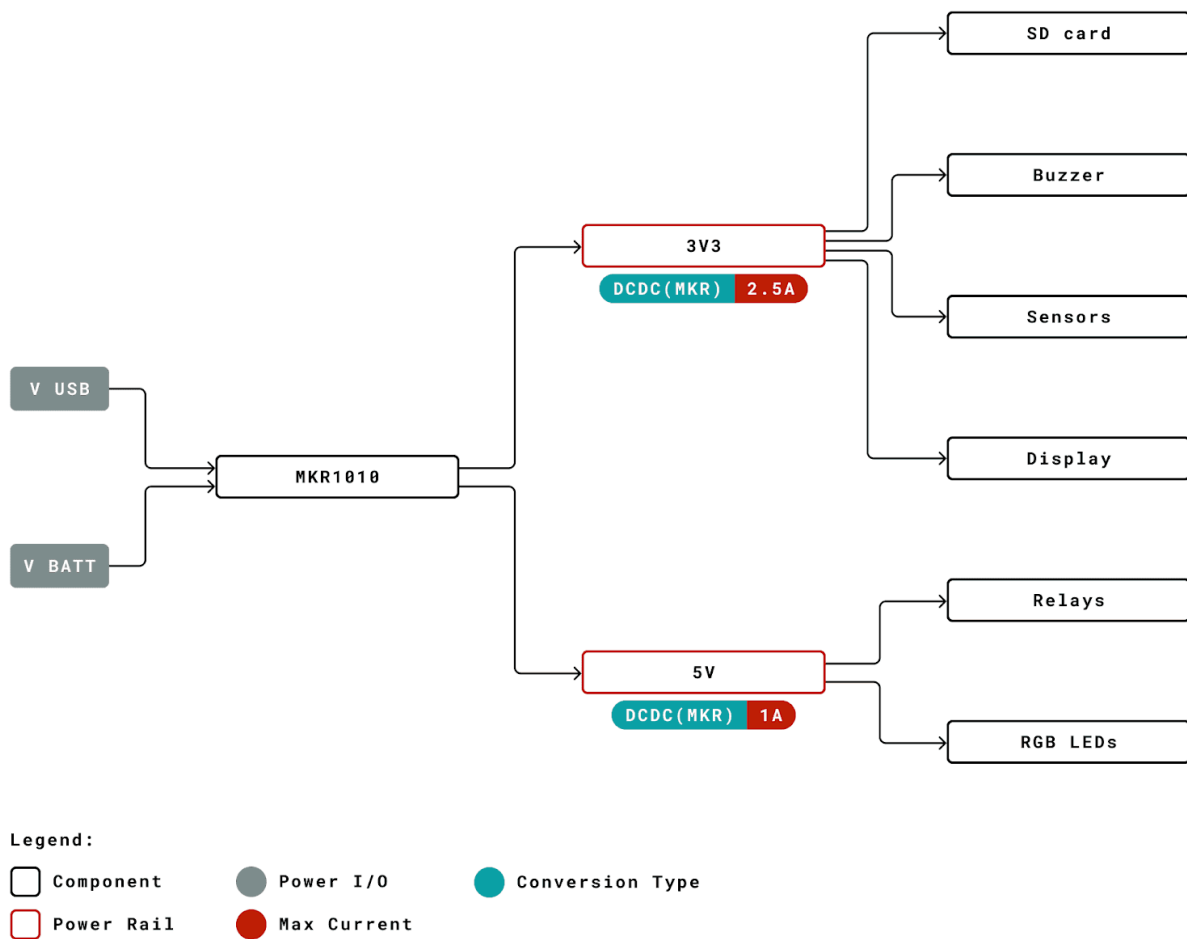

Power tree

## 2.3 Solution Overview

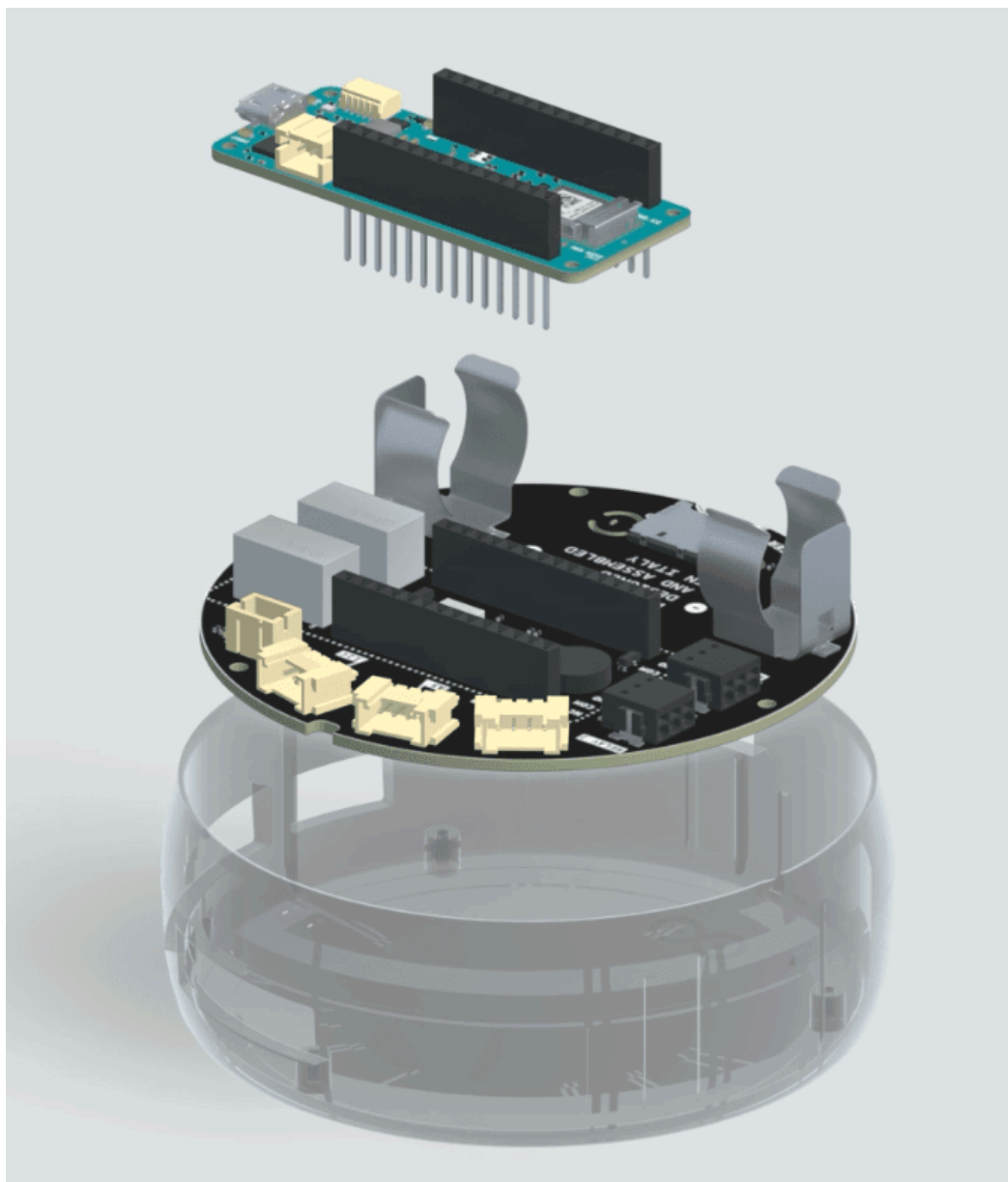

*Solution overview*

The MKR IoT Carrier is also a part of the Arduino® Oplà IoT Kit, that in addition to the carrier contains an MKR WiFi 1010, a motion sensor, moisture sensor, USB cable and a protective case.



## 3 Board Operation

### 3.1 Getting Started - IDE

If you want to program your MKR IoT Carrier while offline you need to install the Arduino Desktop IDE **[1]**. To connect the MKR IoT Carrier to your computer, you'll need a Micro-B USB cable. This also provides power to the board, as indicated by the LED.

### 3.2 Getting Started - Arduino Cloud Editor

All Arduino boards, including this one, work out-of-the-box on the Arduino Cloud Editor **[2]**, by just installing a simple plugin.

The Arduino Cloud Editor is hosted online, therefore it will always be up-to-date with the latest features and support for all boards. Follow **[3]** to start coding on the browser and upload your sketches onto your board.

### 3.3 Getting Started - Arduino Cloud

All Arduino IoT enabled products are supported on Arduino Cloud which allows you to Log, graph and analyze sensor data, trigger events, and automate your home or business.

### 3.4 Sample Sketches

Sample sketches for the MKR IoT Carrier can be found either in the "Examples" menu in the Arduino IDE or in the Oplà IoT Kit platform **[4]** and further documentation can be found in Arduino Documentation **[8]** which also contains links to the troubleshooting articles.

### 3.5 Online Resources

Now that you have gone through the basics of what you can do with the board you can explore the endless possibilities it provides by checking exciting projects on Arduino Project Hub **[5]**, the Arduino Library Reference **[6]** and the online store **[7]** where you will be able to complement your board with sensors, actuators and more

### 3.6 Board Recovery

All Arduino boards have a built-in bootloader which allows flashing the board via USB. In case a sketch locks up the processor and the board is not reachable anymore via USB it is possible to enter bootloader mode by double-tapping the reset button right after power up.

## 4 Connector Pinouts

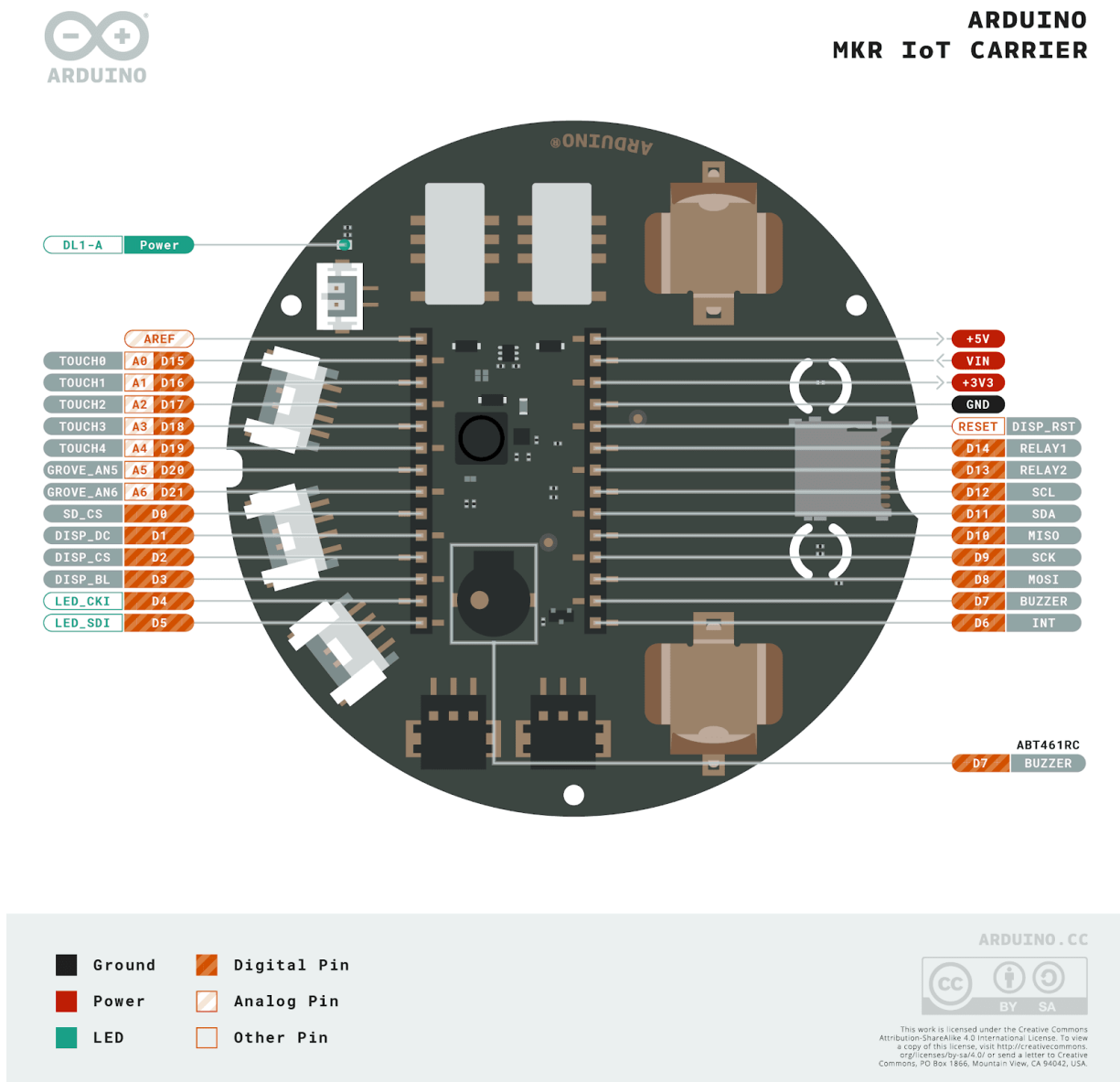

Pinout

Detailed information on the MKR IoT Carrier's pinouts are available in a separate document: MKR IoT Carrier pinout

## 4.1 Battery Clips

Pin	Function	Type	Description
1	GND	Power	Ground
2	VBAT	Power	Positive 18650 Battery Terminal

## 4.2 A5

Pin	Function	Type	Description
1	AN5	Analog	Analog Input 5
2	NC	NC	Not Connected
3	+5V	Power	+5.0V power rail
4	GND	Power	Ground

## 4.3 A6

Pin	Function	Type	Description
1	AN6	Analog	Analog Input 6
2	NC	NC	Not Connected
3	+5V	Power	+5.0V power rail
4	GND	Power	Ground

## 4.4 I2C

Pin	Function	Type	Description
1	SCL	Digital	I2C Clock Signal
2	SDA	Digital	I2C Data Signal
3	+5V	Power	+5.0V power rail
4	GND	Power	Ground

## 4.5 Relay 1 / Relay 2

Pin	Function	Type	Description
1	NC	Switch	Normally Closed
2	COM	Switch	Common
3	NO	Switch	Normally Open

## 5 Mechanical Information

### 5.1 Board Outline / Mounting Holes

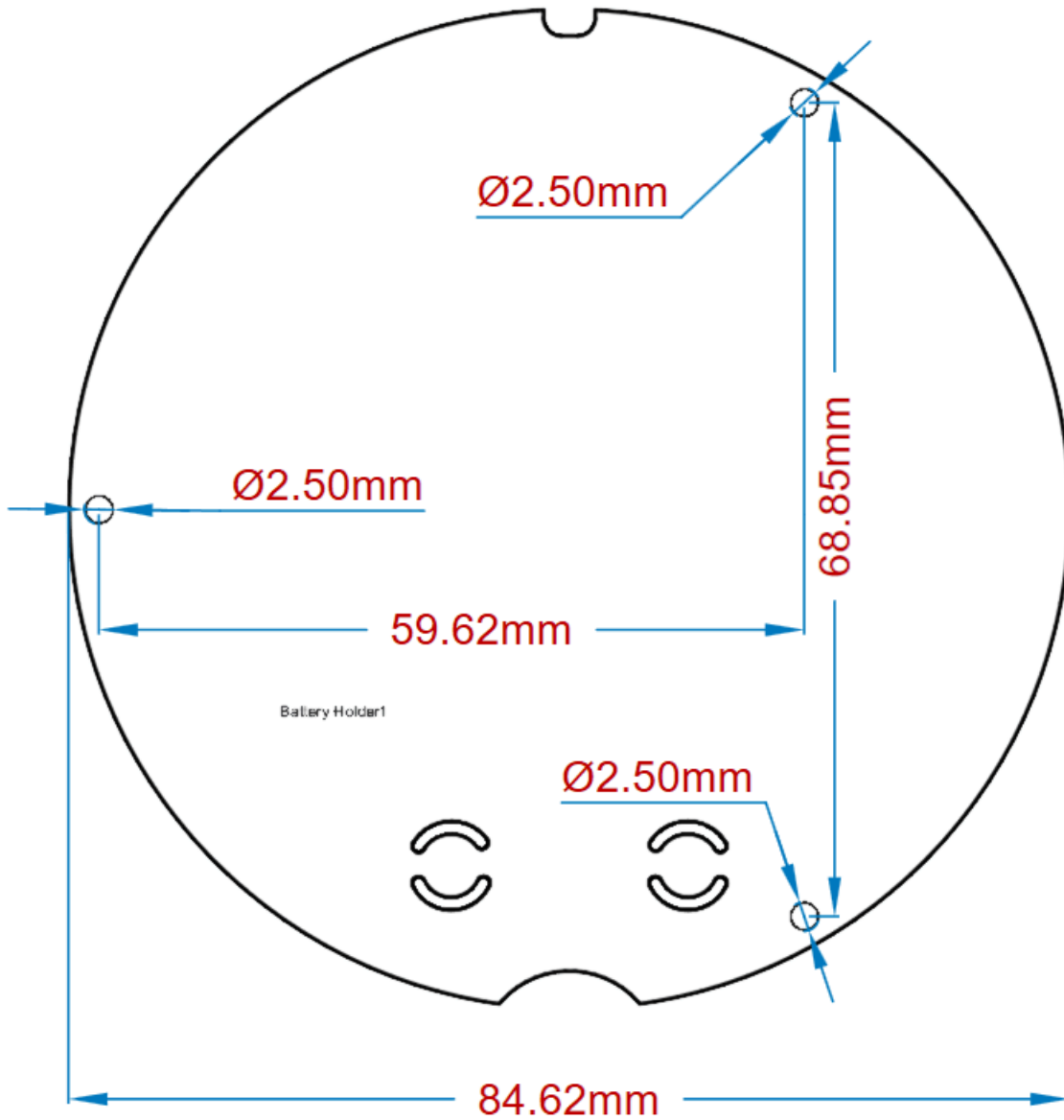

*Mechanical view*

## 6 Ratings

### 6.1 Absolute Maximum Ratings

Symbol	Description	Min	Typ	Max	Unit
T <sub>Max</sub>	Maximum thermal limit <sup>1</sup>	-30	20	85	°C
VBatt <sub>Max</sub>	Maximum input voltage from battery input	3.2	3.7	4.3	V
ARelay <sub>Max</sub>	Maximum current through relay switch	-	-	2	A
P <sub>Max</sub>	Maximum Power Consumption	-	-	5000	mW

## 7 Certifications

### 7.1 Declaration of Conformity CE DoC (EU)

We declare under our sole responsibility that the products above are in conformity with the essential requirements of the following EU Directives and therefore qualify for free movement within markets comprising the European Union (EU) and European Economic Area (EEA).

### 7.2 Declaration of Conformity to EU RoHS & REACH 211 01/19/2021

Arduino boards are in compliance with RoHS 2 Directive 2011/65/EU of the European Parliament and RoHS 3 Directive 2015/863/EU of the Council of 4 June 2015 on the restriction of the use of certain hazardous substances in electrical and electronic equipment.

Substance	Maximum Limit (ppm)
Lead (Pb)	1000
Cadmium (Cd)	100
Mercury (Hg)	1000
Hexavalent Chromium (Cr6+)	1000
Poly Brominated Biphenyls (PBB)	1000
Poly Brominated Diphenyl ethers (PBDE)	1000
Bis(2-Ethylhexyl} phthalate (DEHP)	1000
Benzyl butyl phthalate (BBP)	1000
Dibutyl phthalate (DBP)	1000
Diisobutyl phthalate (DIBP)	1000

Exemptions : No exemptions are claimed.

Arduino Boards are fully compliant with the related requirements of European Union Regulation (EC) 1907 /2006 concerning the Registration, Evaluation, Authorization and Restriction of Chemicals (REACH). We declare none of the SVHCs (<https://echa.europa.eu/web/guest/candidate-list-table>), the Candidate List of Substances of Very High Concern for authorization currently released by ECHA, is present in all products (and also package) in quantities totaling in a concentration equal or above 0.1%. To the best of our knowledge, we also declare that our products do not contain any of the substances listed on the "Authorization List" (Annex XIV of the REACH regulations) and

Substances of Very High Concern (SVHC) in any significant amounts as specified by the Annex XVII of Candidate list published by ECHA (European Chemical Agency) 1907 /2006/EC.

### 7.3 Conflict Minerals Declaration

As a global supplier of electronic and electrical components, Arduino is aware of our obligations with regards to laws and regulations regarding Conflict Minerals, specifically the Dodd-Frank Wall Street Reform and Consumer Protection Act, Section 1502. Arduino does not directly source or process conflict minerals such as Tin, Tantalum, Tungsten, or Gold. Conflict minerals are contained in our products in the form of solder, or as a component in metal alloys. As part of our reasonable due diligence Arduino has contacted component suppliers within our supply chain to verify their continued compliance with the regulations. Based on the information received thus far we declare that our products contain Conflict Minerals sourced from conflict-free areas.

## 8 FCC Caution

Any Changes or modifications not expressly approved by the party responsible for compliance could void the user's authority to operate the equipment.

This device complies with part 15 of the FCC Rules. Operation is subject to the following two conditions:

- (1) This device may not cause harmful interference
- (2) this device must accept any interference received, including interference that may cause undesired operation.

#### **FCC RF Radiation Exposure Statement:**

1. This Transmitter must not be co-located or operating in conjunction with any other antenna or transmitter.
2. This equipment complies with RF radiation exposure limits set forth for an uncontrolled environment.
3. This equipment should be installed and operated with minimum distance 20cm between the radiator & your body.

**English:** User manuals for licence-exempt radio apparatus shall contain the following or equivalent notice in a conspicuous location in the user manual or alternatively on the device or both. This device complies with Industry Canada licence-exempt RSS standard(s). Operation is subject to the following two conditions:

- (1) this device may not cause interference
- (2) this device must accept any interference, including interference that may cause undesired operation of the device.

**French:** Le présent appareil est conforme aux CNR d'Industrie Canada applicables aux appareils radio exempts de licence. L'exploitation est autorisée aux deux conditions suivantes :

- (1) l' appareil n' doit pas produire de brouillage
- (2) l'utilisateur de l'appareil doit accepter tout brouillage radioélectrique subi, même si le brouillage est susceptible d'en compromettre le fonctionnement.

#### **IC SAR Warning:**



**English** This equipment should be installed and operated with minimum distance 20 cm between the radiator and your body.

**French:** Lors de l'installation et de l'exploitation de ce dispositif, la distance entre le radiateur et le corps est d'au moins 20 cm.

**Important:** The operating temperature of the EUT can't exceed 85°C and shouldn't be lower than -40°C.

Hereby, Arduino S.r.l. declares that this product is in compliance with essential requirements and other relevant provisions of Directive 2014/53/EU. This product is allowed to be used in all EU member states.

Frequency bands	Maximum output power (ERP)
863-870Mhz	-3.22dBm

## 9 Company Information

Company name	Arduino S.r.l.
Company Address	Via Andrea Appiani,25 20900 MONZA (Italy)

## 10 Reference Documentation

Ref	Link
Arduino IDE (Desktop)	<a href="https://www.arduino.cc/en/Main/Software">https://www.arduino.cc/en/Main/Software</a>
Arduino IDE (Cloud)	<a href="https://create.arduino.cc/editor">https://create.arduino.cc/editor</a>
Arduino Cloud Editor - Getting Started	<a href="https://docs.arduino.cc/arduino-cloud/guides/editor/">https://docs.arduino.cc/arduino-cloud/guides/editor/</a>
Arduino Oplà IoT Kit	<a href="https://opla.arduino.cc/">https://opla.arduino.cc/</a>
Arduino Project Hub	<a href="https://create.arduino.cc/projecthub?by=part&amp;part_id=11332&amp;sort=trending">https://create.arduino.cc/projecthub?by=part&amp;part_id=11332&amp;sort=trending</a>
Library Reference	<a href="https://www.arduino.cc/reference/en/libraries/arduino_mkriotcarrier/">https://www.arduino.cc/reference/en/libraries/arduino_mkriotcarrier/</a>
Online Store	<a href="https://store.arduino.cc/mkr-iot-carrier">https://store.arduino.cc/mkr-iot-carrier</a>
Arduino Documentation	<a href="https://docs.arduino.cc/hardware/mkr-iot-carrier">https://docs.arduino.cc/hardware/mkr-iot-carrier</a>



## 11 Revision History

Date	Revision	Changes
24/02/2021	1	First Release
17/05/2022	2	Technical updates
26/08/2022	3	IMU ID fix
25/04/2024	4	Updated link to new Cloud Editor